

TML GROUP

Technical Datasheet

UNIDACHS

5



Operating weight: approx. 20.000–22.000 kg,
Diesel drive with 115 kW, alternatively electric drive with 110 kW
Telescopic stroke : 3.500 mm

535

» Technical specifications

Crawler undercarriage	
Crawler chain	D4D
Base plates	Triple grouser, HD, 600 mm
Gradability	41 %
Draw bar pull	105 kN
Ground pressure	7.0 t/m ² (600 mm base plates)
Drive system	Stepless hydrostatic traction drive, independent drive for each track side
Brakes	Spring set, hydraulically released wet multi disc brake
Parking brake	Wet multi-disc brake, wear-free, automatic activation when joystick is in neutral position
Travel speed	0 – 2.6 km/h

Tyre mounted undercarriage	
Tyres	10.00 – 20 Twin tyres
Gradability	17 %
Outriggers	4 pcs. (proportional) With outrigger relief
Drive system	4-wheel drive, front axle rigid, rear axle steering with hand pump for emergency brake release
Brakes	Hydraulic brake system
Steering	Hydraulic circuit for steering axle
Ground pressure	12.0 t/m ² on tyres 8.7 t/m ² on outriggers
Travel speed	19 km/h

Hydraulic system	
Type	Load-Sensing
Operating pressure	330 Bar
Hydraulic oil tank capacity	250 Liter
Safety system	Pipe break protection on the lifting cylinders
Pump type	Variable displacement pump
Filtering	Hydraulic return filter and tank breather filter
Control block	Additional working circuits for attachments optionally available

Diesel drive	
Diesel engine (EU/USA)	DEUTZ AG, Stage V, 4 cylinders, Diesel engine with diesel oxidation catalyst and particulate filter AdBlue Tank capacity:10 liters
Diesel engine (non EU/USA)	DEUTZ AG, USA Tier 3, EU Stage IIIA, 4 cylinders, Diesel engine with diesel oxidation catalyst
CO ₂ -neutral operation	Possible with paraffinic diesel fuel according to EN 15940
Rated power	115 kW (EU/USA) 124 kW (non EU/USA)
Engine capacity	4.100 cm ³ (EU/USA) 4.700 cm ³ (Non EU/USA)
Torque	610 Nm at 1.600 min ⁻¹
Cooling	Fluid
Air Filter	2-stage, with electrical contamination indicator
Fuel tank capacity	260 Liter

Electro drive 3-Phase (alternative)	
Rated power	90 kW at 50 Hz 90 kW at 60 Hz
Voltage	380 V, 400 V oder 500 V
Frequency	50 Hz or 60 Hz

535

» Technical specifications

Upper structure

Hydrostatic slew drive with axial piston motor and planetary gear.

Rotation 360°, continuous, endless

Rotation speed 0 – 5.7 min⁻¹

Slewing brake Spring set, hydraulically released wet multi disc brake

Cradle & Telescopic boom

Telescopic boom with integrated rotating unit. Fully enclosed design to protect the hoses and the tool cylinder against radiation heat and falling objects.

Max. range 10,200 mm

Telescopic stroke 3,500 mm

Rotation 360°, continuous endless

Boom rotation speed 0 – 14 min⁻¹

Boom rotation torque 27 kNm

Pull and push force 130 / 152 kN

Tool ripping force 71 kN

Boom guide rollers 18 pcs.

Lighting

Upper structure front 2 x LED headlights

Upper structure rear Optional

Cradle 1 x LED headlight

Surrounding warning light 1 x Yellow

Electrical system

System voltage 24 V

Battery 2 Pcs.

Paint

Undercarriage Black, RAL 9005

Upper structure & Telescopic boom Yellow, RAL 1007

Radio remote control

Operation via 2 joysticks. Illuminated colour display. Waist belt carrying system.

Weight 4.5 kg

Operator's cabin

Cabin Closed cabin, FOPS - Falling Object Protective Structure, robust safety front guard with fine-wire mesh in front of the wind screen against heat radiation heat

Heating and air conditioning Air conditioning and heating installed

Driver's seat Mechanically spring suspended, fully adjustable comfort seat. Joysticks are mounted on armrest, lap belt, pilot safety lever on driver's seat.

Glazing Heat-resistant safety glass

Monitoring Display: Indication of current machine data, automatic monitoring of operating status

Surround noise level LWA 103 db (A)

Inside cab noise level LpA 75 db (A)



RELIABLE



PRODUCTIVE

UNIDACHS - The best answer to extreme conditions

Crawler undercarriage	5 Series Heavy Metal	5 Series Hard Rock
Chain sealed with lifetime lubrication	●	●
Base plates, Triple grouser, 600 mm	●	●
Base plates, Triple grouser, 800 mm	○	○
Rubber vulcanized tracks	○	○
Rubber pads for base plates	○	○
2nd driving stage for two driving speeds	○	○
Towing circuit	○	○
Front clearing blade	○	○

Tyre undercarriage (P version)	5 Series Heavy Metal	5 Series Hard Rock
Undercarriage with tyre running gear and 4-point outriggers. Twin tyres 10.00 – 20.00	●	●
Front clearing blade (2-point outriggers instead of 4-point support)	○	○

Upper structure	5 Series Heavy Metal	5 Series Hard Rock
Rotation 360°, continuous endless	●	●
Central lubrication system for upper structure and cradle	○	○
Arctic Pack (hydraulic oil, engine and fuel preheating)	○	○
Rear and side bumper	○	○
Fire extinguishing system	○	○
Hand-held fire extinguisher (6 kg) in protective box, attached to the upper structure	○	○
Refuelling pump	○	○
Connection for external starting aid	○	○
Additional emergency stop switch	○	○
Main isolator switch for electrical system	●	●
Service doors lockable	●	●
Crane lifting points	●	●
Engine compartment lighting	○	○

Key: ● Standard ○ Option



Unidachs 535 - Electric furnace outbreak



Unidachs 535 - Tundish cleaning

UNIDACHS Series 5

Operator's cabin	5 Series Heavy Metal	5 Series Hard Rock
Lockable, spacious, sound-insulated driver's cab manufactured in accordance with the latest ergonomic requirements	●	●
Large high-resolution control unit with colour display, versatile setting, control and monitoring options	●	●
Air conditioning	●	●
Comfort seat with lap belt	●	●
Safety glass windows	●	●
FOPS Safety guard, front screen	●	●
Heat protection wire mesh screen	●	○
Storage compartments	●	●
FOPS Safety guard, roof	○	○
Hand-held fire extinguisher (cabin)	●	●
First aid kit	●	●
Tool kit	●	●
Auxiliary heating system	○	○
Dust protection system	○	○
Bullet proof front screen	○	○
Bullet proof roof window	○	○
Tilttable driver's cab (30° tilttable)	○	○
Camera system 270° Bird View (consisting of 3 cameras)	○	○
Camera system (1x rear camera / 1x right hand side camera)	○	○
Additional radio remote control	○	○

Key: ● Standard ○ Option

Drive unit options	5 Series Heavy Metal	5 Series Hard Rock
Diesel engine, 115 kW, 4 cylinders, EU Stage V / USA Tier4final	●	●
Diesel engine 115 kW (non EU/USA)	●	●
Electric drive, 90kW with 25m cable	○	○
Radio remote Control	5 Series Heavy Metal	5 Series Hard Rock
Remote control via radio transmission	●	●
Remote control via cable	●	●
2 Joysticks	●	●
Illuminated colour display	●	●
Operating mode selector switch	●	●
Single-hand drive mode	●	●
Tool control	●	●
Radio frequency 16 channels 433/434 MHz	●	●
Radio frequency 16 channels 535 MHz	○	○
Radio frequency 16 channels 461 MHz	○	○
Emergency stop button on transmitter unit	●	●
Hip belt carrying system	●	●
Accessoires	5 Series Heavy Metal	5 Series Hard Rock
Emergency first aid kit	●	●
Storage compartments	●	●
Tool kit	●	●



UNIDACHS 535



UNIDACHS 535P

UNIDACHS Series 5

Cradle & Telescopic Boom	5 Series Heavy Metal	5 Series Hard Rock
Telescopic stroke 3,500 mm	●	●
Rotation 360°, continuous, endless	●	●
Dirt deflector between main boom and inner boom	○	●
Covers for boom guide rollers	○	○
Additional hose tray for hydraulic or pneumatic tools	○	○
Bumper plates main Boom	○	●
Central lubrication system cradle	○	○
Overload warning system	○	○

Lighting	5 Series Heavy Metal	5 Series Hard Rock
Lighting package: 2x LED work lights upper structure front, 1x LED work light cradle, 1x LED rotating beacon yellow	●	●
Extended lighting package: 2x LED worklights cabin roof, , 1x LED worklight cradle	○	○
Lighting package: 2x LED worklights upper structure front, 2x LED worklights upper structure rear, 2x LED worklights cab roof, 3x LED worklights cradle, 1x LED rotating beacon yellow	○	●
Additional LED lighting	○	○
Blue spot light in the rear area	○	○
Safety perimeter ground marking Red light projection	○	○

Attachment tools	5 Series Heavy Metal	5 Series Hard Rock
Boom extension integrated	○	○
Boom extension bolted	○	○
Single ripper hook	○	○
Double ripper hook	○	○
Hydraulic hammer	○	○
Pneumatic hammer	○	○
Rotary drum cutter	○	○
Demolition shears	○	○
Hydraulic grab	○	○
Various sized buckets	○	○
Ditching bucket	○	○
Ripper bucket	○	○
Back hoe bucket	○	○
Drilling attachment	○	○
Mechanical quick coupler	○	○
Concrete spray nozzles	○	○
Bow setting device	○	○
Single-point lifting bail	○	○
Porous plug pusher	○	○
Tap hole drill	○	○
EBT-Drill	○	○

Key: ● Standard ○ Option

535

» Kinematics and dimensions

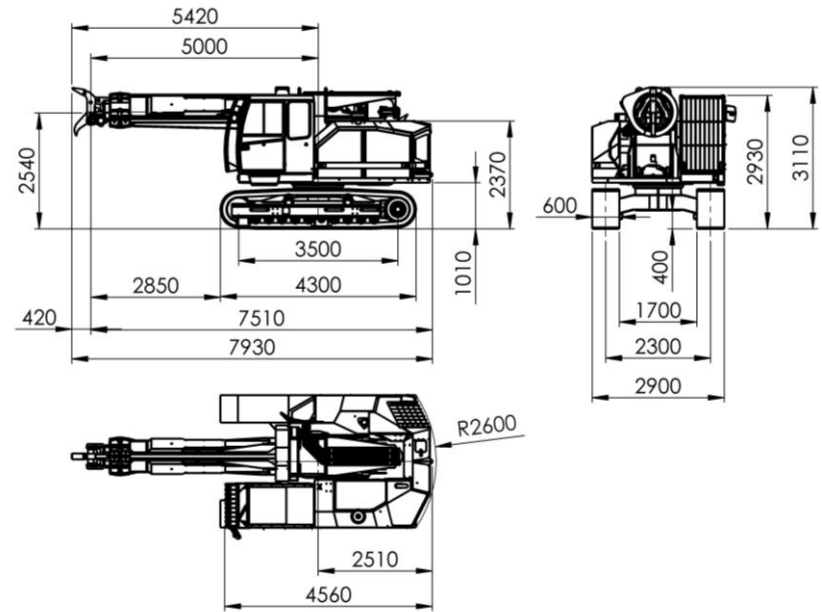
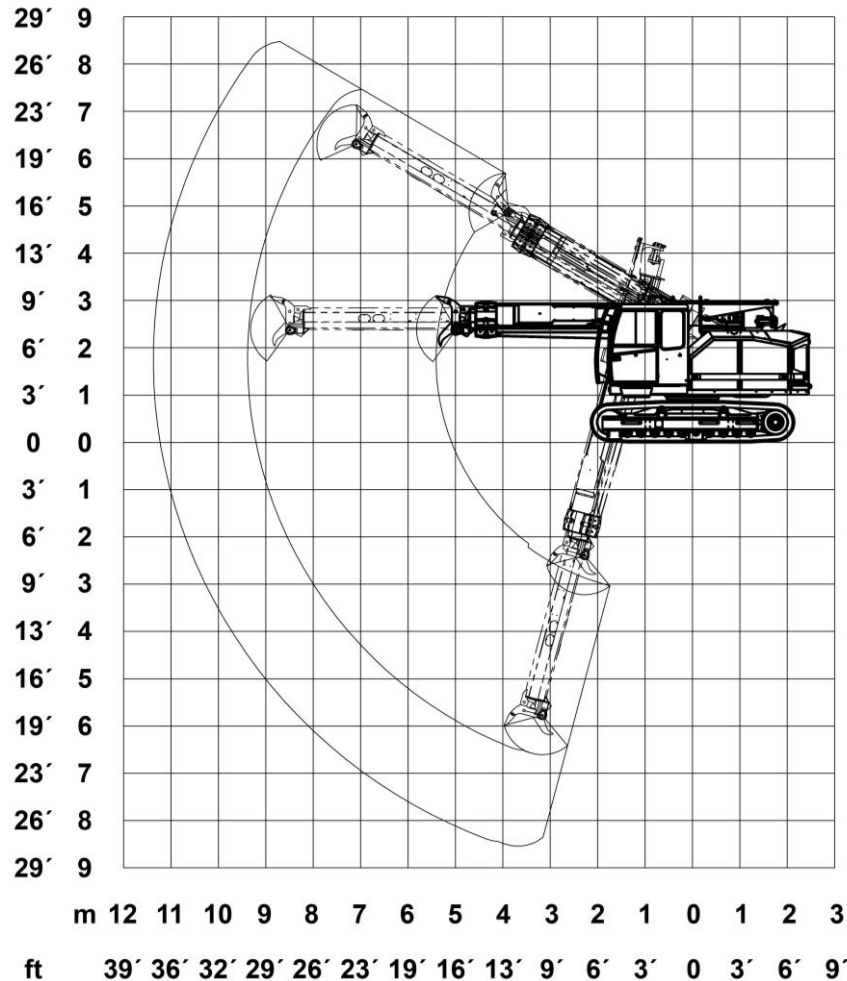

535P

» Kinematics and dimensions

